

Consumer Unit Design 30 RCCB Incomer

For the distribution of power in a residential application, conforming to BS EN 61439-3 including Annex ZB (16kA rating).

Design 30 is the enhanced board for use in applications where the consumer unit is located in a living area of the dwelling. The board is designed to allow compliance with BS 7671:2008 regulations; 411.3.3 additional protection by means of a 30mA RCD, 522.6.202 protection of wiring concealed in walls or partitions.

Metal enclosure manufactured to allow compliance with BS 7671 regulation 421.1.201

RCCB incomer boards are generally used as sub distribution boards in residential applications where all outgoing circuits share the same 30mA RCD protection.

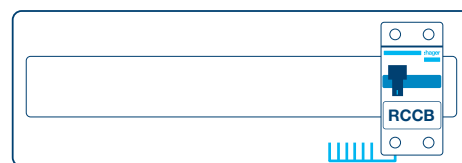
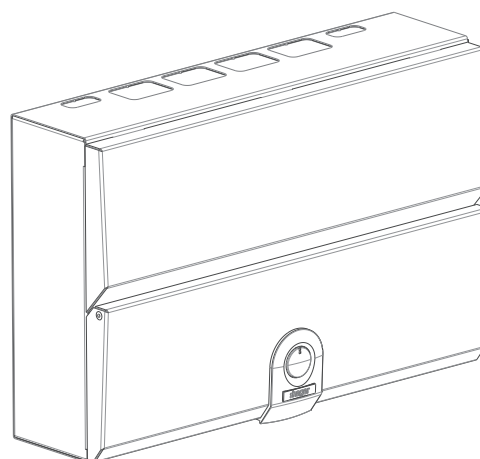

VM306H

Description	Size	Cat ref.	Cat ref. with Knockouts
2 Way 40A 30mA RCCB Incomer	2	VM402H	VM402HK
6 Way 63A 30mA RCCB Incomer	3	VM406H	VM406HK
6 Way 100A 30mA RCCB Incomer	3	VM306H	VM306HK
10 Way 63A 30mA RCCB Incomer	4	VM410H	VM410HK
10 Way 100A 30mA RCCB Incomer	4	VM310H	VM310HK
14 Way 100A 30mA RCCB Incomer	5	VM314H	VM314HK

Features & Benefits

- Cable clamp - Secures supply cables on entry to main incoming device preventing any movement being transmitted through metertails to device
- Square cable entry points top and bottom for use with cable trunking (references available with or without knockouts)
- Rear Knockouts for ease of cable entry – Cable protector plate provided
- Rigid top wall – Enhances rigidity to prevent distortion when removing knockouts
- Locate and hold cover - allows use of both hands whilst fixing cover
- Front cover retained screws – Prevents loss during installation
- Full metal DIN rail – Secure and stable attachment of devices
- Quick release clip on MCB/RCBO – Allows removal of MCB/RCBO with busbar still in place
- Optimised cabling space – DIN rail position allows maximum cabling space
- Top mounted terminal rail makes the wiring of the neutral and earth connections neat and simple.
- Health and Safety lock allows the door to be secured with circuits isolated during construction (via accessory, see overleaf).
- Torque settings displayed inside front cover so they're easily accessible by the electrician.
- Lockable front door via an accessory (see overleaf).

Technical Characteristics

Standards	BS EN 61439-3
Classification	Consumer Unit
Rated & Operational Voltage (U_n/U_e)	230V a.c 50 Hz
Rated Insulation Voltage (U_i)	320V a.c. 50Hz
Rated Frequency (fn)	50 Hz
Rated impulse withstand voltage (U_{imp})	4kV
Rated Current of the Assembly (I_{na})	40A/63A/100A
Rated Current of an Outgoing Circuit I_{nC}	MCB 6A-63A (Marked Rated Current on Device)
Rated Conditional Short Circuit of the Assembly (I_{cc})	Annex ZB: 16kA rms at 250V, power factor 0.6 with equipment and arrangements specified in Hager's technical documentation/catalogue
Protection against electric shock	Consumer Unit shall be installed in an electrical system conforming to IEC 60364 / BS 7671
Rated Diversity Factor (RDF) / Values of assumed loading	2 Way to 3 Way - 0.8, 4 Way to 5 Way - 0.7, 6 Way to 9 Way - 0.6, 10 Way and above - 0.5

Note: RDF only applies to continuously and simultaneously loaded circuits. In principle, this means adjacent circuit breakers having a load on time exceeding 30 minutes or where a load not exceeding 30 minutes has an 'off' time less than the 'on' time will need to have the rated diversity factor applied as indicated.

Pollution Degree	2
Types of System Earthing for which the assembly is designed	TNC-S and TN-S when installed in an electrical system conforming to BS 7671
Intended locations	Indoor use only
Stationary assembly	
Degree of protection	IP2XC with door open / closed and full compliment of devices / blanks fitted. Note: Where cables are installed through the top wall of the enclosure, gaps of IP4X to be maintained.
Intended use	Intended for use in domestic (residential) or similar premises
Electromagnetic compatibility (EMC) classification	EMC environment B
External design	Wall mounted, surface type, enclosed assembly.
Mechanical impact protection	IK05
Type of construction	Fixed parts
Incoming Line/Neutral terminal (80 - 100A board)	50mm ²
Incoming Line/Neutral terminal (63A board)	25mm ²
Incoming Earth Terminal	16mm ²

Warranty - Hager undertakes to replace or repair at its discretion products should they become inoperable within the time periods as stated. - 2 Years

Accessories

Cable protector plate	Provides protection for cables entering from the rear of the board	VM02CE
Health and safety lock	Provides the ability to lock the consumer unit during the installation process	VMHBL
Design 30 door locking kit	Allows the board to be lockable	VMLOCK
Grommet strip	For protecting cables against damage when entering the board	VM05GS
Rear stand off plates	To stand consumer unit off wall allowing surface mounted cables to enter through rear of unit.	VM01SP

Devices

MCB 6kA 6A to 63A B Curve

MTN***

Design 30 Dimensions (mm)

	Enclosure Size			
	2	3	4	5
Height	240	240	240	240
Width	149	221	293	364
Depth	102.5	102.5	102.5	102.5

	Number of Knockouts			
<input type="checkbox"/> *Top Face 30 x 25 (mm)	2	2	2	2
<input type="checkbox"/> *Top Face 40 x 30 (mm)	0	2	4	4
<input type="checkbox"/> Back 100 x 50 (mm)	1	1	1	3
<input type="checkbox"/> *Bottom Face 30 x 25 (mm)	2	3	4	4

* References with a 'K' suffix feature top and bottom square knockouts.

