

Consumer Unit Design 10 Configurable

For the distribution of power in a residential application, conforming to BS EN 61439-3 including Annex ZB (16kA rating).

Design 10 is the entry level board designed for all applications and allows compliance with BS 7671:2008 regulations; 411.3.3 additional protection by means of a 30mA RCD, 314.1&2 segregation of circuits to avoid danger and minimise inconvenience in the event of a fault, 522.6.202 protection of wiring concealed in walls or partitions.

Metal enclosure manufactured to allow compliance with BS 7671 regulation 421.1.201

A configurable board allows the installer flexibility to separate the circuits across the two RCCB's without being forced to maintain an even number of circuits across each device.

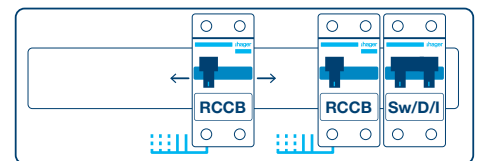
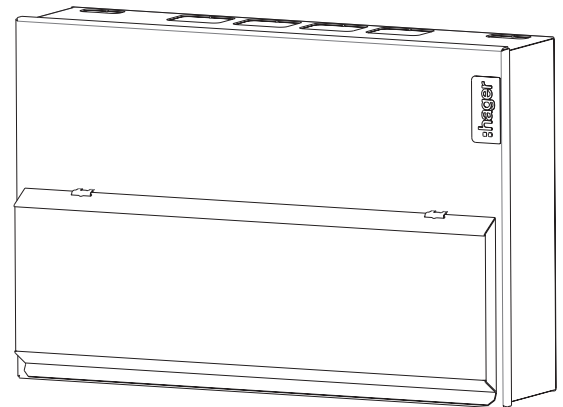

VML710C

Description	Size	Cat ref.
10 Way Split Load Configurable 100A Switch 2x63A 30mA RCCB	5	VML710C
16 Way Split Load Configurable 100A Switch 2x63A 30mA RCCB	6	VML716C
10 Way Split Load Configurable 100A Switch 2x80A 30mA RCCB	5	VML810C
16 Way Split Load Configurable 100A Switch 2x80A 30mA RCCB	6	VML816C

Features & Benefits

- Square cable entry points top and bottom for use with cable trunking
- Rear Knockouts for ease of cable entry – Cable protector plate available as an accessory
- Rigid top wall – Enhances rigidity to prevent distortion when removing knockouts
- Front cover retained screws – Prevents loss during installation
- Full metal DIN rail – Secure and stable attachment of devices
- Quick release clip on MCB/RCBO – Allows removal of MCB/RCBO with busbar still in place
- Optimised cabling space – DIN rail position allows maximum cabling space
- Top mounted terminal rail makes the wiring of the neutral and earth connections neat and simple.
- Torque settings displayed inside front cover so they're easily accessible by the electrician.

Technical Characteristics

Standards	BS EN 61439-3
Classification	Consumer Unit
Rated & Operational Voltage (U_n/U_e)	230V a.c 50 Hz
Rated Insulation Voltage (U_i)	320V a.c. 50Hz
Rated Frequency (fn)	50 Hz
Rated impulse withstand voltage (U_{imp})	4kV
Rated Current of the Assembly (I_{na})	100A
Rated Current of an Outgoing Circuit I_{nC}	MCB 6A - 63A (Marked Rated Current on Device)
Rated Conditional Short Circuit of the Assembly (I_{cc})	Annex ZB: 16kA rms at 250V, power factor 0.6 with equipment and arrangements specified in Hager's technical documentation/catalogue
Rated Current of outgoing unit (I_{nC})	RCCB 63A - 80A (marked rated current on device)
Protection against electric shock	Consumer Unit shall be installed in an electrical system conforming to IEC 60364 / BS 7671
Rated Diversity Factor (RDF) / Values of assumed loading	10 way and above - 0.5
Note: RDF only applies to continuously and simultaneously loaded circuits. In principle, this means adjacent circuit breakers having a load on time exceeding 30 minutes or where a load not exceeding 30 minutes has an 'off' time less than the 'on' time will need to have the rated diversity factor applied as indicated.	
Pollution Degree	2
Types of System Earthing for which the assembly is designed	TNC-S and TN-S when installed in an electrical system conforming to BS 7671
Intended locations	Indoor use only
Stationary assembly	
Degree of protection	IP2XC with door open / closed and full compliment of devices / blanks fitted. Note: Where cables are installed through the top wall of the enclosure, gaps of IP4X to be maintained.
Intended use	Intended for use in domestic (residential) or similar premises
Electromagnetic compatibility (EMC) classification	EMC environment B
External design	Wall mounted, surface type, enclosed assembly.
Mechanical impact protection	IK05
Type of construction	Fixed parts
Incoming Line/Neutral terminal	50mm ²
Incoming Earth Terminal	16mm ²

Warranty - Hager undertakes to replace or repair at its discretion products should they become inoperable within the time periods as stated - 2 Years.

Accessories

Cable protector plate	Provides protection for cables entering from the rear of the board	VM02CE
Cable Clamp	Secures supply cables on entry to main incoming device	VA10MT
Grommet strip	For protecting cables against damage when entering the board	VM05GS
Rear stand off plates	To stand consumer unit off wall allowing surface mounted cables to enter through rear of unit.	VM01SP

Devices

MCB 6kA 6A to 63A B Curve

MTN***

Design 10 Dimensions (mm)

	Enclosure Size	
	5	7
Height	246	246
Width	370	478
Depth 1	83	83
Depth 2	100	100

	Number of Knockouts	
<input type="checkbox"/> Top Face 30 x 25 (mm)	2	2
<input type="checkbox"/> Top Face 40 x 30 (mm)	4	6
<input type="checkbox"/> Back 100 x 50 (mm)	3	3
<input type="checkbox"/> Bottom Face 30 x 25 (mm)	4	5

