

ZD0817

Meter Tail Clamp allows the incoming supply cables to be secured to prevent any strain on the cables from being transmitted to the incoming device. Hager recommend this accessory for use on TT systems.

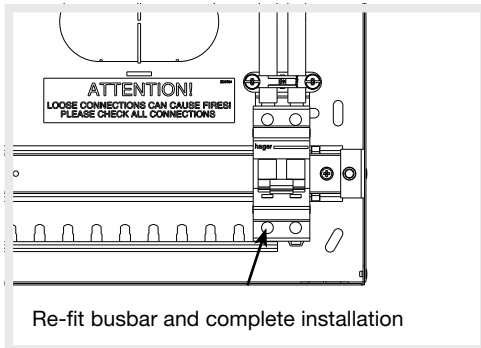
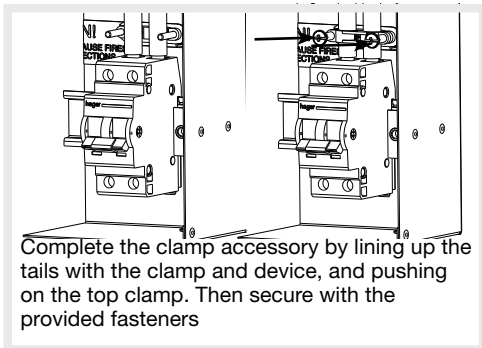
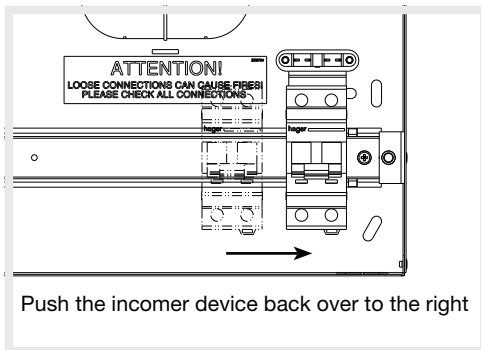
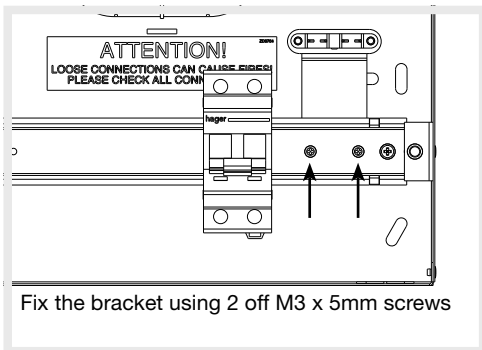
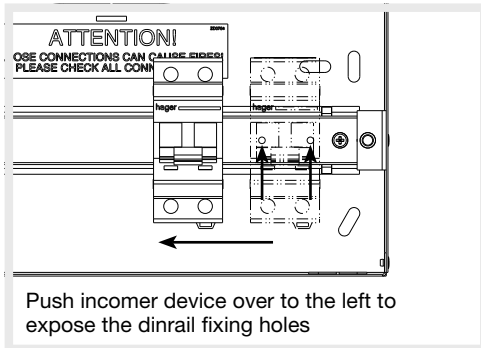
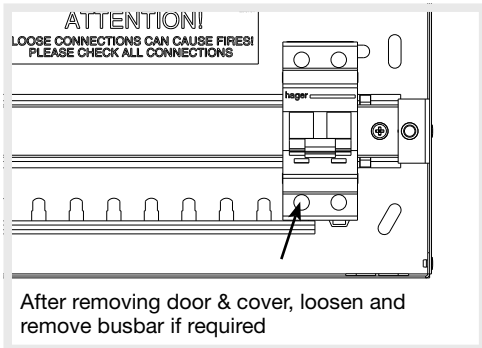

ZD0817