

6LE009017B

XEM510, XEM520

- Danger of death by electric shock.** Live components carry potentially fatal voltages.
- Before starting any installation or maintenance work, switch off the power to the distribution board and secure to prevent it being switched on again accidentally.
 - Make sure that the conductors to be connected to the meter are voltage-free.
 - All installation and maintenance work on this unit must be carried out by a trained and authorised electrician.

The Local Load Manager is supplied with power via outer conductor L1. At least the outer conductor L1 and neutral conductor N need to be connected for the unit to switch on.

1. Introduction

This product makes it possible to manage a cluster of charging stations for electric cars. It is able to adapt the charging power of electric vehicles according to the consumption of the building (dynamic management) or according to a fixed value (static management). It avoids an electrical shutdown of the building due to an overload.

The product is also able to manage access to the charging station by configuring RFID badges and manage different charging modes.

An „open“ access is accessible for the end user, in order to check in real time the availability of the terminals.

2. Documentation

The latest and complete documentation is available on <https://hgr.io/r/XEM510> or <https://hgr.io/r/XEM520>



3. Safety instructions

- Danger of death by electric shock.**
- Live components carry potentially fatal voltages.
 - Only use the Local Load Manager in a dry environment and keep it away from liquids.
 - Install the Local Load Manager only in approved enclosures or distribution boards downstream of the electricity supply company's meter so that the connections for the outer and neutral conductors are located behind a cover or guard to prevent accidental contact.
 - Before starting any installation or maintenance work, switch off the power to the distribution board and secure to prevent it being switched on again accidentally.
 - Maintain the prescribed minimum distances between the network cable and mains voltage installation components or use suitable insulation.

- Avoid damage to or destruction of the Local Load Manager**
- Do not connect an ISDN cable to the Local Load Manager's network connection.
 - **Damage to or destruction of the Local Load Manager by voltage surges on the network cable.**
 - If network cables are installed outside the building, voltage surges can be caused by lightning strike, for example.
 - If installed outside the building, the network cable must be protected with suitable overvoltage protection.
 - **Damage to or destruction of the Local Load Manager by improper use.**
 - Do not operate the Local Load Manager outside the specified technical tolerances.
 - The LAN1/2 Ethernet interface of the connected unit must meet the safety extra low voltage requirements.
 - For outdoor use, install an network isolator on the LAN1/2 Ethernet input of the product.

4. Technical data

Interfaces	LAN (10/100 Mbit) RS485 (half-duplex, max. 115200 baud)
Protection class	II
Overvoltage category	III
IP	IP2X
Connection cross section in line with EN 60204	10-25 mm ² * * Mechanical: 1.5-2.5 mm (e.g. for connecting external current transformers)
Tightening torque for screw terminals	2.0 Nm
Weight	0.3 kg
Dimensions	88 x 70 x 65 mm
Ambient temperature in operation (direct measurement)	-25 °C...+45 °C
With reduced measuring current IN < 32 A (direct measurement)	-25 °C...+55 °C
Ambient temperature during transportation / storage	-25 °C...+70 °C
Relative humidity (non-condensing)	Up to 75 % as an annual average, up to 95 % on up to 30 days/year
Max. altitude during operation	2000 m above sea level
Degree of pollution	2
Usage	Indoor use only or in a waterproof enclosure
Mains power supply	
Starting current	< 25 mA
Supply voltage / frequency	110 V ~ ±10 % / 60 Hz ± 5% or 230 V ~ ±10 % / 50 Hz ± 5%
Internal consumption P _{max}	5.0 W
Measuring current circuit for measurement category III	
Limit current I _N / phase	63 A
Rated voltage	max. 230/400 V ~
Frequency range	50/60 Hz ± 5 %

5. Operation of the Local Load Manager at ambient temperature of 55°C

The Local Load Manager must not be run continuously at ambient temperatures of 55 °C. If such condition can be present, please consider the usage of Current Transformer and to install the Local Load Manager in an appropriate environment.

- Danger of death by electric shock or fire** Live components carry potentially fatal voltages. If the ambient temperature exceed 45°C:
- Electrical protection must not exceed 32 A.
 - External current transformers should be used for higher currents.
 - The Local Load Manager must be connected with cables that are at least 10 mm² in cross section and no less than 1 m long.

6. Product description

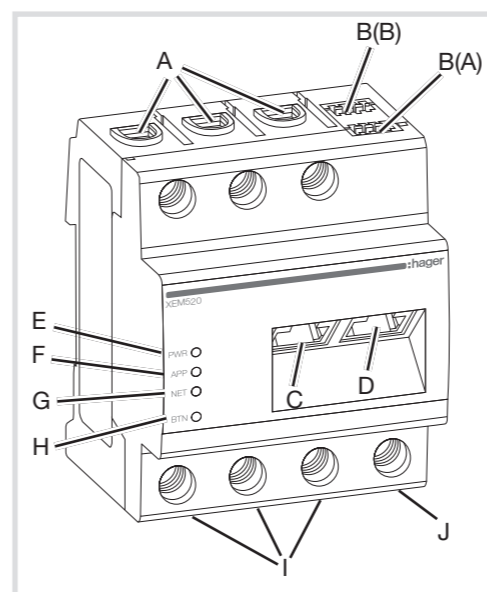

A	Outer conductors, L1, L2, L3 outputs
B(A)	RS485 modbus RTU connection
B(B)	Not used
C	Connection Ethernet LAN1 (switch mode)
D	Connection Ethernet LAN2 (switch mode)
E	PWR: Power LED
F	APP: Application LED
G	NET: Network LED
H	BTN: Button (reset)
I	Outer conductors, L1, L2, L3 Inputs
J	Neutral conductor N

7. Modbus interface

Note the following points when connecting external devices to the RS485 Modbus RTU interface of the Local Load Manager.

- Controller:**
Requirement for the cable:
- Nominal voltage/wire insulation: 300 V RMS
 - Cable cross section: 0.25 ... 1.5 mm²
 - Cable type: Rigid or flexible
 - Recommendation: Use AlphaWire standard cable, designation 2466C. Alternatively, a CAT5e cable can also be used.

- Requirement for cable installation:**
- In the area for connecting the RS485 Modbus RTU interface on the Local Load Manager, mechanical means must be provided to ensure that individual wires of the connecting cable are at least 10 mm away from live parts.
 - The connecting cable must be run separately from the mains cables in the distribution board and on the permanent link.
 - The RS485 Modbus RTU interface of the connected unit must meet the safety extra low voltage requirements.

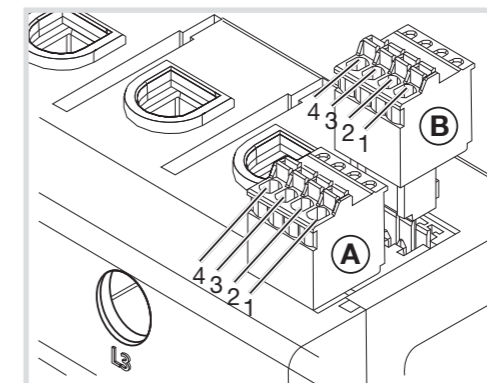

Connection diagram for RS485 connector:

Pin	Description	Color
1	Not used	
2	Com. / C/C' / OVL	Brown
3	D1 / B/B' / (+)	Green
4	D0 / A/A' / (-)	Yellow

i Maximal modbus cable length = 10 m.

8. Led statuses

Power LED		
Colour	Status	Description
Green	Flashing	Device is starting.
Green	On	Application launched correctly and running.
Orange	Flashing	Application on update. Try to realize a hardware reboot.
Orange	On	Application not launched: an issue appears in application lifecycle. Try to realize a hardware reboot. If system doesn't go back to normal, please take contact with hager support.
Red	On	Application / System Dead: Try to realize a hardware reboot. If system doesn't go back to normal, please take contact with hager support.
Application LED		
Colour	Status	Description
Green	On	Installation is running.
Orange	On	Product not fully configured.
Red	On	Critical error occur, see hager website https://hgr.io/r/XEM520 or https://hgr.io/r/XEM510
Orange	Flashing rapidly	Date and time are not synchronizing, connect to the webserver in order to solve the issue.
Network LED		
Colour	Status	Description
/	Off	No connection.
Green	On	Internet connected.
Green	Flashing rapidly	Admin password set to default during 10 min (press between 2 and 4 seconds).
Orange	On	No internet connection.
Red	On	Network issue: conflict on IP, no address got from DHCP server...

9. Electrical connection for direct measurement

It must be ensured by fitting the according protection that the maximum permitted current per phase (63A) is not exceeded.

1. Install the Local Load Manager on a DIN rail.

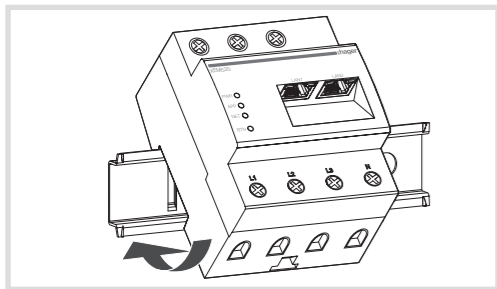

2. Connect the conductors to the Local Load Manager. Do not exceed the permitted connection cross section and tightening torque for the screw terminals (see section "4. Technical data"):

- For a three phase power network, connect the outer conductors L1, L2 and L3 and the neutral conductor N to the Local Load Manager as shown in the connection diagram.
- For a single phase power network, connect the outer conductor L1 and neutral conductor N to the Local Load Manager as shown in the connection diagram.

The following figure contains a connection example.

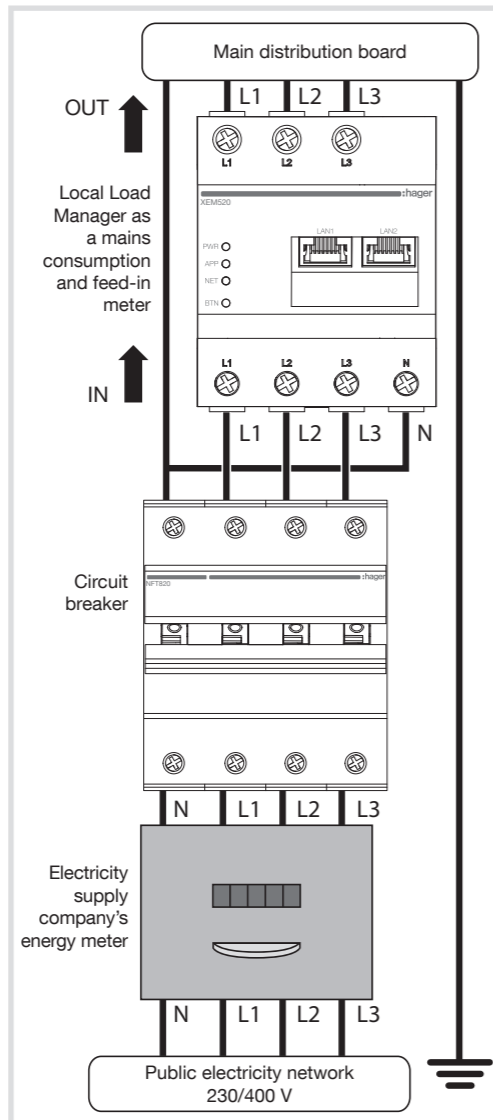

10. Electrical connection for indirect measurement with current transformers

1. Install the Local Load Manager on a DIN rail. To do this, hook the device onto the top edge of the DIN rail and press down until it latches into place.
2. Connect a current transformer to each outer conductor L1, L2 and L3.

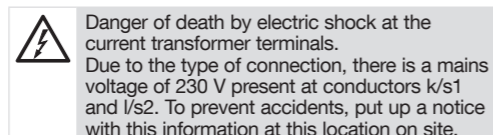

3. Connect a cable for the secondary current measurement to terminals k/s1 and l/s2 on each current transformer. Do not exceed the permitted connection cross section for the Local Load Manager (see section "4. Technical data").
4. Connect the connecting cable for the current measurement to the Local Load Manager and do not exceed the permitted tightening torque for screw terminals (see section "4. Technical data").
5. Connect the connecting cables for the voltage measurement to the outer conductors L1, L2 and L3.

The following figure contains a connection example.

Figure: Connection for indirect measurement with current transformers

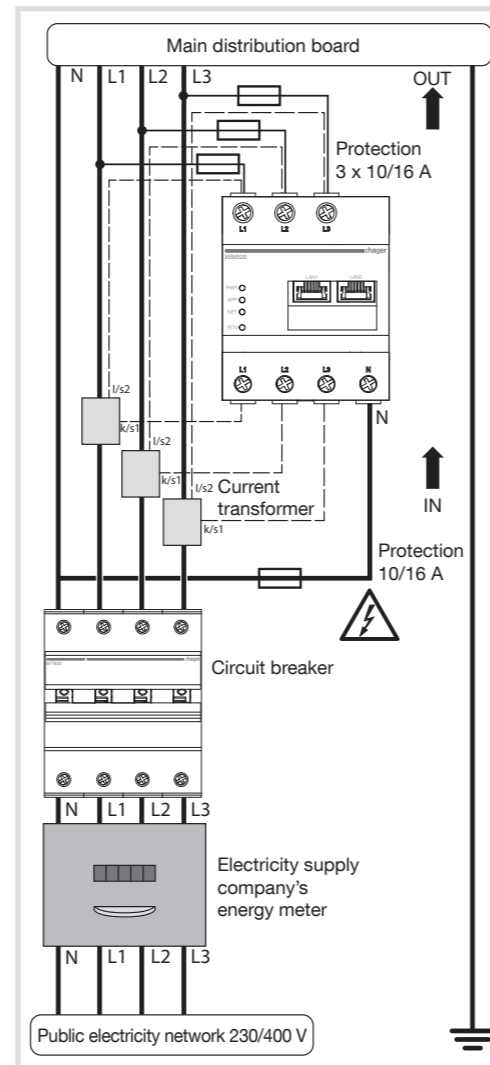

- Use HAGER brand current transformers with a secondary current of 1A or 5A.
- In case of static load management, it's not necessary to plug the current transformers. The power supply of the product is enough.

Designation	Explanation
L1, L2, L3	Outer conductor
N	Neutral conductor
OUT	Meter output, distribution board side
IN	Meter input, mains side

11. Start the web interface

- Connect a PC on the same network of the Local Load Manager (or directly on it).

- Be sure that your IP address is in the same range of the Local Load Manager.

- Type the address `http://hager-llm-[6last_characters_SUID].local/` (example: `http://hager-llmab4df5.local/`) in the address field of your internet browser. You can find this address in the QR code on the front of the product.

- Type the default credentials : admin / 1234
- Let's configure the product.

- Check if you have the latest version of the software, before configuring. If not, you can find it on the Hager website.

12. Hardware reboot, network settings and admin password reset

Use a pointed object to press the BTN button:

After 2s, the NET LED will first blink green and the admin password will be „1234“ for 10 minutes. After this time, if no action were down, the product will go back in run mode and the password will stay as before this mode.

Keep pressing after 4s, then the NET LED will blink in red, release now to go back to factory network settings. A reboot will occur.

Keep pressing after 7s to realize an hardware reboot. all Local Load Manager's LED will switch off, now release.

13. Fault finding

The PWR LED does not light up.

The Local Load Manager is not being supplied with power.

- Make sure that at least the top/outer conductor L1 and the neutral conductor N are connected to the Local Load Manager.

The NET LED lights up red.

The IP configuration isn't set properly.

- Check the ethernet cable connection
- Check the IP addresses.
- Restart the Local Load Manager.

The APP LED flashes orange or red.

Orange: an alert occur on the installation, see <https://hgr.io/r/XEM510> or <https://hgr.io/r/XEM520> to see the detail.

Red: a critical error occur on the installation, see hager website <https://hgr.io/r/XEM510> or <https://hgr.io/r/XEM520> to see the detail.

- Restart the Local Load Manager could solve the issue.

14. Environmentally-friendly disposal

Dispose of the Local Load Manager in accordance with the electronic waste disposal regulations that apply on site.

15. Open source licenses

This product also contains open source software that was developed by third parties. This relates, in particular, to the GPL and LGPL licenses.

You will find the license text and associated notes on the Local Load Manager user interface.